

Guidance Note GN2

Constant Flow Regulators

INTRODUCTION

This Guidance Note deals with the commissioning of constant flow regulators (also known as “automatic balancing valves”) in heating and cooling systems. The constant flow regulator is only one of the methods currently being specified or used by installation contractors as a means of saving time in the commissioning of water distribution systems. Other methods such as Differential Pressure Control Valves are also being used in variable volume systems.

It is the responsibility of commissioning engineers to be aware of and responsive to such developments and to adapt to the new technologies becoming available. This Guidance Note is intended as a source of advice to commissioning specialists on the application of Constant Flow Regulators and on problems which may be encountered in their use.

CONSTANT FLOW REGULATORS

The Constant Flow Regulator (CFR) is a device which maintains a constant flow rate regardless of pressure fluctuations within a water distribution system. The device is either of the cartridge type or of the externally adjustable type, each of which has its advantages and disadvantages. The cartridge type consists of an inner cartridge which is either of stainless steel or plastic construction.

The cartridge has special profiles within the sides and end that allow water to flow through it. Flow area is restricted as the differential pressure increases. This is achieved either by a piston compressing against a spring, thus reducing flow area, or a diaphragm rolling action progressively covering the available flow area.

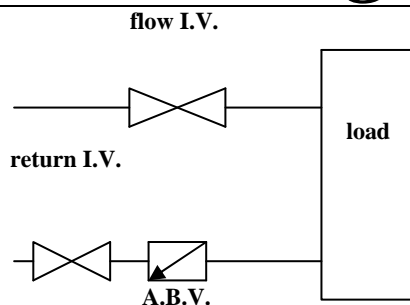

Automatic balancing device in circuit

The profiled piston type devices react to increasing differential pressure, compressing the spring, which allows the piston to move in the direction of flow thus reducing the annular area around the piston available for the flow.

SYSTEM DESIGN & DEVICE SELECTION

Although the CFR's are installed to remove any need to visit each terminal to adjust the flow, there is still a requirement to measure the flowrates on each branch to check that the correct cartridges have been installed. To do this effectively the use of metering stations on main and sub-branches is recommended.

CFR's are not affected by turbulence and do not require particular lengths of straight pipe up and down stream so can operate close to a bend, coupling or other fitting.

Depending on manufacturer and type, CFR's are selected using a table of flow or set to the required constant flow rate by adjustment of the internal cartridge or are externally adjusted. When using the table of flow rates, the design flow rate required by the designer is unlikely to be matched exactly by the selected cartridge. In such cases, the maximum flow rate of the cartridge should always leave a margin of adjustment over the particular design flow rate required. Where this margin is inadequate the next larger device in the range should be selected.

The adjustable cartridge type of device is more dependent on metering stations being installed at strategic points so that the flow rates can be checked. The externally adjustable type can be set from graphs or by simply dialling up the design flowrate once the unit has been installed.

IDENTIFYING THE DEVICE

Before any checking of flow rates can be carried out, the devices must be identified and visual confirmation made that they have been installed the correct way round and in the return pipework (see above sketch & pictures following). Installation in the return pipework is generally recommended to reduce the effects of entrained air. The installation should also be checked to ensure that provision has been made for maintenance access.

FLUSHING & CLEANING

Flushing and chemical cleaning should be carried out in accordance with BSRIA Application Guide AG8/91 – Pre-Commissioning Cleaning of Water Systems. If a flushing by-pass is not included and the system is to be flushed/cleaned, then the cartridges must be removed from the CFR's to allow adequate flushing velocities to be achieved in the system. Manually adjustable valves should be set to the full flow position.

NB. One manufacturer's device requires that a separate cap (with no regulating device) is fitted for this exercise.



Oventrop's Hydromat Q

COMMON OPERATING FAULTS & REMEDIES

Once the system has been successfully flushed and is operating satisfactorily, checks can be made at the metering stations to establish flow rates. If any checked flow rate is not equal to the sum of the set flows of the cartridges on that branch, or the reading is not within the +/- 5% stipulated by the manufacturers, then an investigation to establish which device(s) is not performing correctly has to be carried out to determine the cause. This method will vary depending on individual manufacturer's devices, but a general procedure is as follows:

- a) Shutting off each individual device in turn and subtracting the design flow for it from the aggregate branch flow rate will indicate the suspect device(s).
- b) Once the suspect device(s) has been located then the design flowrate for it can be established from the manufacturer's tag. If this corresponds with the schedule that the commissioning engineer is working to, i.e. you have the right device in the right place, it may be that the problem lies within the device itself.
- c) The next check that should be carried out is to establish the pressure differential across the device, as all of them have a range within which they operate correctly.
- d) If the pressure differential is within the specified range then the next step is to isolate and drain the section of the system containing the device and remove it for inspection (if the cartridge is of the fixed flow design then the manufacturer's reference on the end of the unit can be compared with those on the tag. If the cartridge is an adjustable type, the setting of the cartridge can be compared with the manufacturer's table).
- e) If the cartridge and tag match a final check is to test the action of the cartridge by depressing the plunger to ensure that the mechanism is working properly and that the spring is not broken.

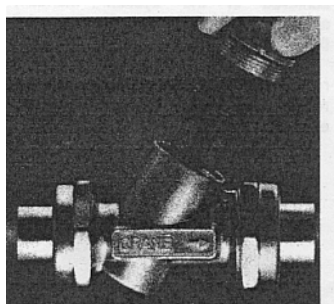

The Crane D960 Automatic Balancing Valve

- f) When all of the above have been tried without success the only remaining option is to request a new cartridge from the manufacturer.
- g) Where the flowrate on manually operated devices differs from that shown on the valve or from graphs, it can be adjusted until the design flowrate is achieved. If, after adjustment, the flowrate remains unchanged, contact the manufacturer.

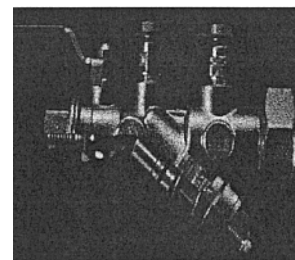

The Hattersley Automatic Balancing Valve

TROUBLE SHOOTING GUIDE

| <u>Problem</u> | <u>Pressure Differential</u> | <u>Cause</u> |
|---|--|--|
| Low flow | Less than CFR control range (see table below) | a) Insufficient pump duty b) Blocked strainer or other restriction to flow. c) Partially closed I.V. |
| Low flow | Within CFR control range | Incorrect or faulty cartridge |
| Excessive flow | Less than CFR control range | a) Cartridge not fitted b) Cartridge fitted the wrong way round. |
| Excessive flow | Within CFR control range | a) Cartridge not pushed fully home against stop. b) Flushing by-pass open c) Incorrect or faulty cartridge |
| Excessive flow | More than CFR control range | Excessive pump head |
| Incorrect flow, but matching another device of same size. | Within CFR control range | Incorrect cartridge fitted |
| Noisy in operation | more than 200 kPa but less than 414 kPa | Higher spring range cartridge needed |
| Chattering in operation | Fluctuating pressure differential (just under the CFR control range) Fluctuating pressure (within the CFR control range). | Pump head too low Excessive air in the system |

CFR Pressure Differential Control Ranges

| <u>Manufacturer</u> | <u>Product No.</u> | <u>Control Range</u> |
|---------------------------------------|--------------------|----------------------|
| Hattersley (Standard cartridges) | 1050/1051 | 17-200 kPa |
| Hattersley (High pressure cartridges) | 1050/1051 | 35-414 kPa |
| Crane sizes A & C | D960 | 22-200 kPa |
| Crane sizes B & D | D960 | 30-410 kPa |
| Oventrop | Hydromat Q | 50-200 kPa |
| BREFCO (now by Crane as D970) | Flowcon | 20-200 kPa |

For further information on the above products contact the CSA office or the manufacturers.

*This Guidance Note was compiled for the CSA Technical Committee by M. Lowe, Hattersley Newman Hender Ltd.
Published by the:
Commissioning Specialist Association, January 1998.
Copyright CSA 1998*

For details of other CSA Publications and Guidance Notes contact the CSA Secretary on: Tel: 01403 754133 E-mail: office@csa.org.uk

or write to: **CSA**
The Old House
24 London Road
HORSHAM
West Sussex
RH12 1AY